



# **MÉMORIAL DE LA PAIX**

**CENTENAIRE DE L'ARMISTICE DU 11 NOVEMBRE 1918**

**CONCOUR D'IDÉE DES ÉTUDIANTS DE L3 - ATELIER CHAVANNES FAVÉ**

**2018/2019**



## LE COLLECTIF

Chacun est un spécialiste dans sa discipline mais ne connaît que peu de chose sur celle de son voisin. Les architectes connaissent l'architecture, les informaticiens l'informatique, les industriels l'industrie, les sculpteurs la sculpture... Le collectif Rosati a pour but de rompre les barrières entre les disciplines afin de favoriser l'innovation et de développer les savoir-faires. Le collectif est basé à Arras mais il est présent en France, en Angleterre et en Chine. Il est constitué d'entreprises, d'indépendants et d'associations impliquées dans l'art, l'architecture et les nouvelles technologies.

## LES AMBITIONS

Un siècle se sera bientôt écoulé depuis la fin de la première guerre mondiale.

Ce concours vise à célébrer le centenaire de l'armistice de manière vivante et innovante en invitant les architectes et designers du monde entier à exprimer leur créativité.

La fin de la guerre marque le début de la période de reconstruction. L'ampleur des dégâts provoque l'essor d'une nouvelle technique: le béton armé. Celle-ci va bouleverser l'économie de la construction et les codes de l'architecture du XXe siècle.

Cent ans plus tard, l'impression 3D dans le bâtiment est en train d'amener un bouleversement des codes de la construction d'une ampleur similaire. Afin de s'inscrire dans la lignée de l'évolution technologique d'après-guerre, nous demandons aux participants de réfléchir à cette nouvelle technique et d'en explorer le potentiel à travers leur proposition de mémorial de la paix.

## SITE

**Le choix du site est laissé libre aux participants. Le projet doit cependant s'inscrire dans un site du Pas-de-Calais en lien avec l'histoire de la première guerre mondiale. Ainsi les étudiants, à la suite de recherches théoriques historiques ont fait le choix de leur propre lieux d'expression, en milieu rural ou urbain.**

■ *Collectif Rosati*

- 01**<sup>P.6</sup> ■ DUMAZ Claire, **EVANESCENCE**
- 02**<sup>P.7</sup> ■ ROBINSON Donan, **SPLEEN**
- 03**<sup>P.8</sup> ■ TROUSSIER Léa, **ARCHE D'ILLUSION**
- 04**<sup>P.9</sup> ■ VANRAPENBUCH François, **COMMEMORATOIR**
- 05**<sup>P.10</sup> ■ CORDIER Margot, **MÉMOIRE DE CORPS**
- 06**<sup>P.11</sup> ■ ROUXEL Quentin, **SOIGNER**
- 07**<sup>P.12</sup> ■ HUNG Chiao-Ying, **3 ÉLÉMENTS**
- 08**<sup>P.13</sup> ■ BERTIN Maxime, **BELVEDERE**
- 09**<sup>P.14</sup> ■ MUCHA Fabiola, **CICATRICES**
- 10**<sup>P.15</sup> ■ HAZARD Manon, **LA RENCONTRE**
- 11**<sup>P.16</sup> ■ PRUD'HOMME Théophile, **L'EMPREINTE**
- 12**<sup>P.17</sup> ■ RAVENEAU Mélissa, **DISPERSION**
- 13**<sup>P.18</sup> ■ MORICE-JAN Dorine, **RECONSTRUCTION**
- 14**<sup>P.19</sup> ■ ONILLON Bastien, **ASCENSION**
- 15**<sup>P.20</sup> ■ ANCELIN Paul, **EXODE**
- 16**<sup>P.21</sup> ■ BLANCHARD Mazarine, **LE REFUGE**
- 17**<sup>P.22</sup> ■ TARDIVEL Clémence, **SPLINE**
- 18**<sup>P.23</sup> ■ BOURGEOIS Jimmy, **LIAISON**
- 19**<sup>P.24</sup> ■ LEMIALE Antoine, **NOEUD D'ÉCOUTE**

- P.25  
AMADE Marie, ANAMNESE ■ **20**
- P.26  
GOURMELEN Enora, ARBRES DE VIE ■ **21**
- P.27  
RIMAUD Pierre, LA CLAIRIÈRE ■ **22**
- P.28  
ALLÉGRINI Lysa, UN RUBAN DE PAIX ■ **23**
- P.29  
NDIOR Chérif, ESPOIR ■ **24**
- P.30  
COUILLARD Margaux, TRAVERSEE ■ **25**
- P.31  
OLEKSIEJ Pierre, MONT SAINT-ELOI ■ **26**
- P.32  
BONANOMI Leonardo, L'AVENIR ■ **27**
- P.33  
ARROYO Matias, BATAILLE DE LOOS ■ **28**
- P.34  
STRAUSSMANN Julia, WHAT IS WAR ? ■ **29**
- P.35  
BELLIER Antoine, THE DOOR ■ **30**
- P.36  
LE BERRE Sarah, L'OMBRE DU BEFFROI ■ **31**
- P.37  
LAOUAR Liam, SENTIER BATTU ■ **32**
- P.38  
RADAS Thomas, MEMORIAL DE LA PAIX ■ **33**
- P.39  
POIRAUD Baptiste, NOUVEAUX VESTIGES ■ **34**
- P.40  
ARMSTRONG Christopher, OBÉLISQUE ■ **35**
- P.41  
EL HADRI Dikra, WAR SPIRAL ■ **36**
- P.42  
SCHONFELDER Leonhard, WELTBÜRGER ■ **37**
- P.43  
LOEWER Stella, SOLAR CUBE ■ **38**

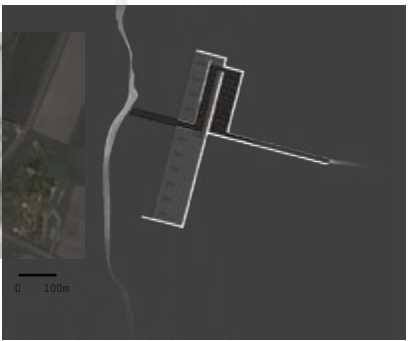
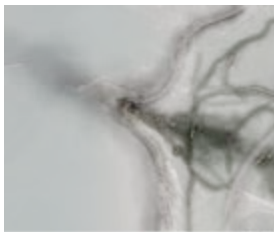
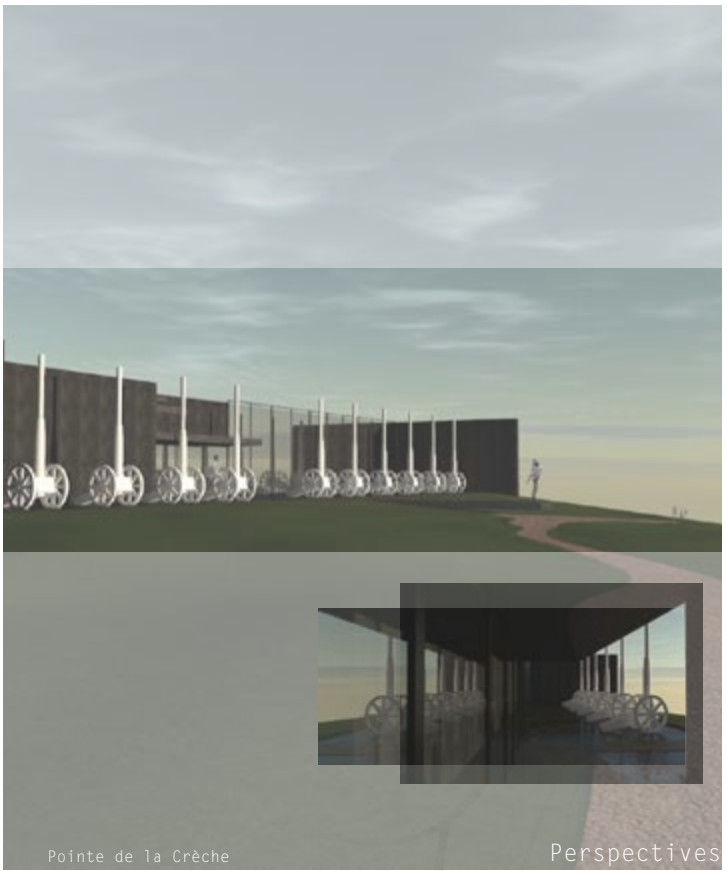

Plan masse

Plan

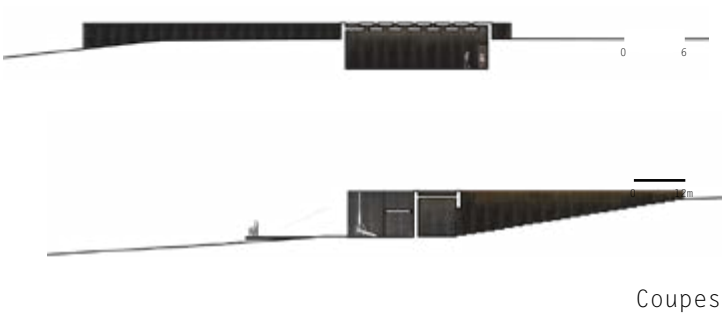

Storyboard

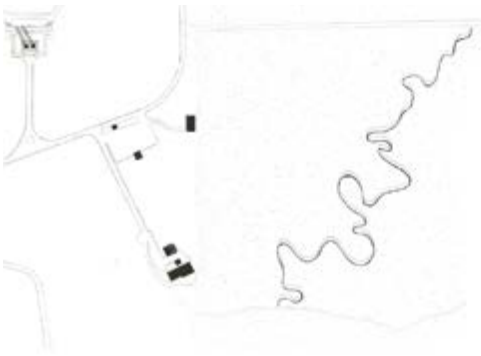



Perspective



Plan



Coupe



Schéma





Perspective



Plan

Plan masse



Coupes Paysagères

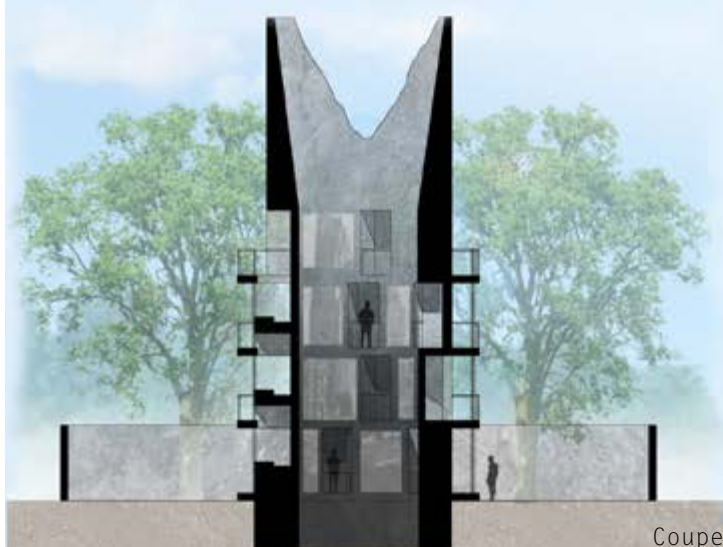

Coupe



Grand Place Arras

Perspective

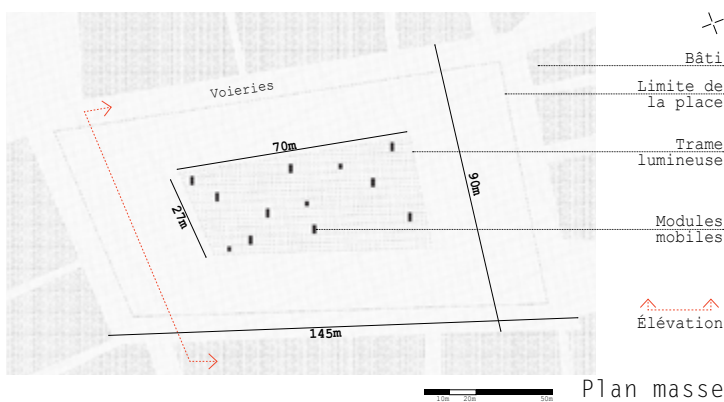

Plan masse



Scénarios d'élévation

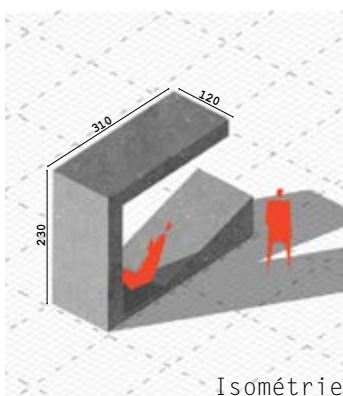

Isométrie



Perspective



Plan



Coupes

Des murs se rejoignant au front mais se prolongeant jusqu'aux pépinières...



Des secours dépassés prolongés à l'arrière...

Des murs opaques, laissant deviner sans percevoir exactement le paysage...



Où l'on entrevoit les horreurs de la guerre...

Des murs fragiles, que chacun peut consolider



Tenant de soigner ce qu'ils peuvent

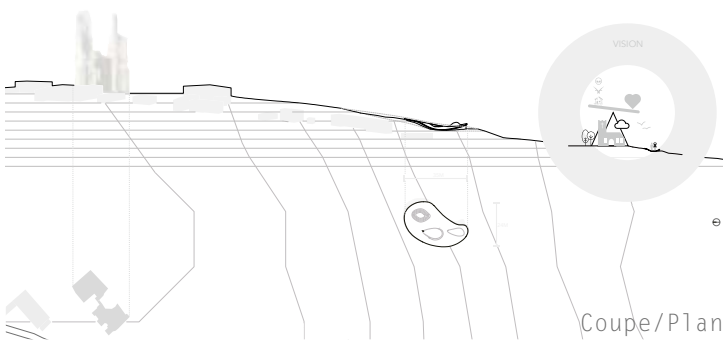
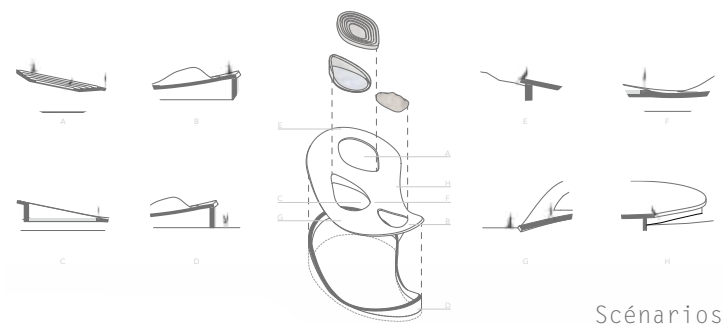

DÉCONSTRUCTIVISME

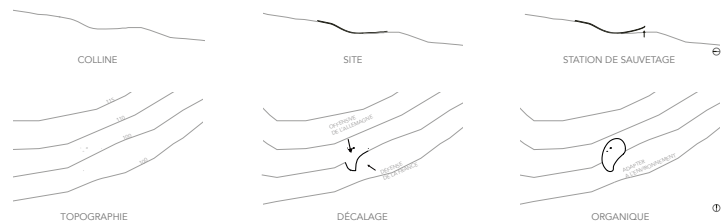

COUPE	ISOMÉTRIQUE	3 ÉLÉMENTS	MATERIALITÉ	SENSATION	SYMBOLE
			EAU	CALME	RÉFLÉXION
			BÉTON	SÉRIEUX	CICATRICE
			CRAIE	RÉGIONAL	MORT

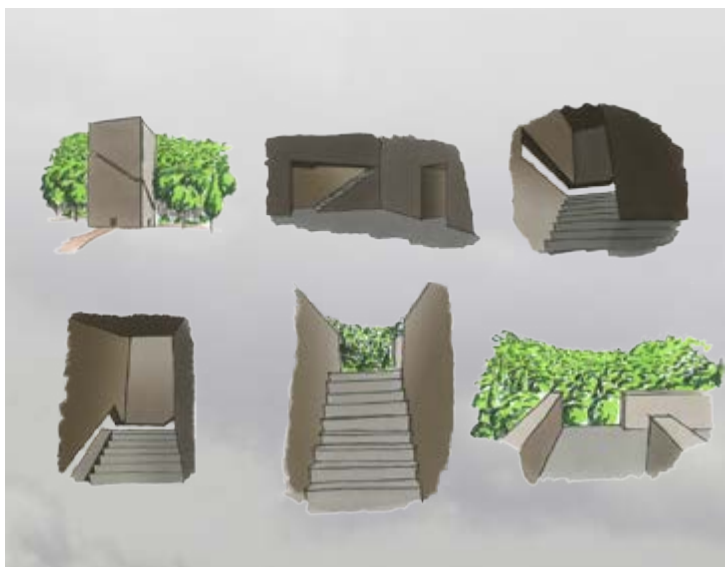



Perspective

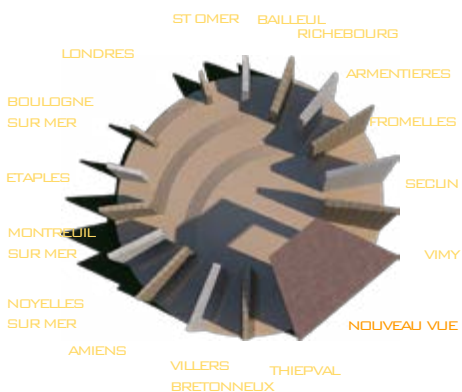

Plan



Coupes



Storyboard



Perspective

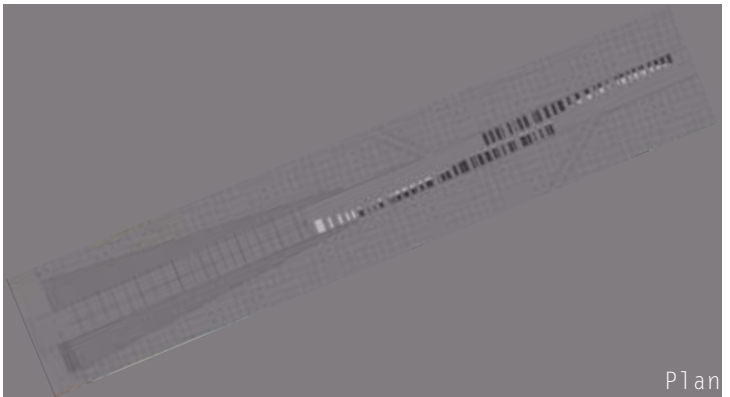

Plan



Plan masse & croquis



perspective elevation

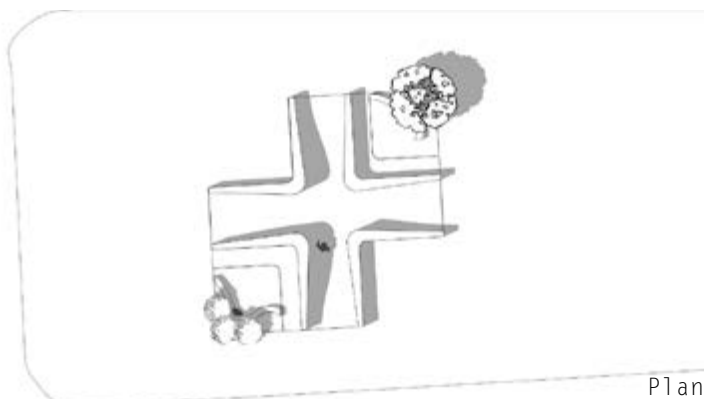

Plan

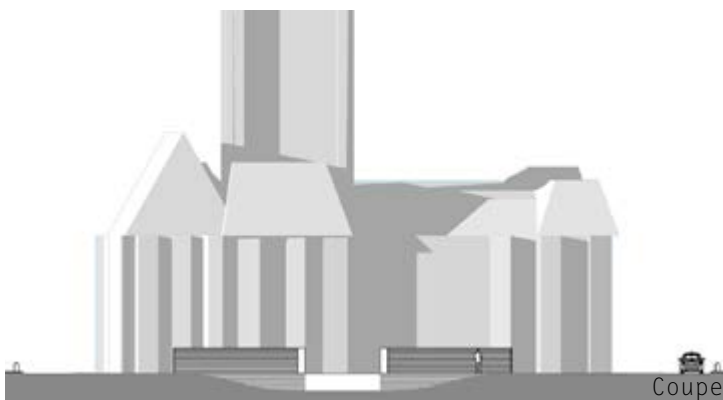

Coupe

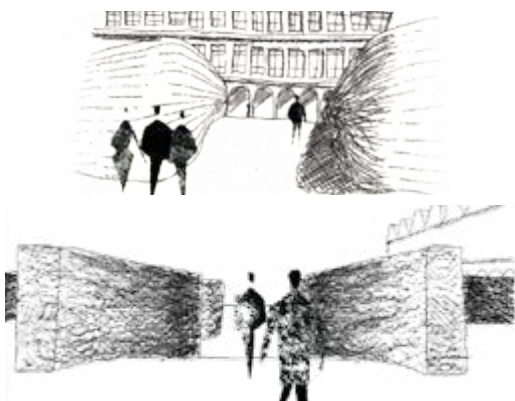

Schémas



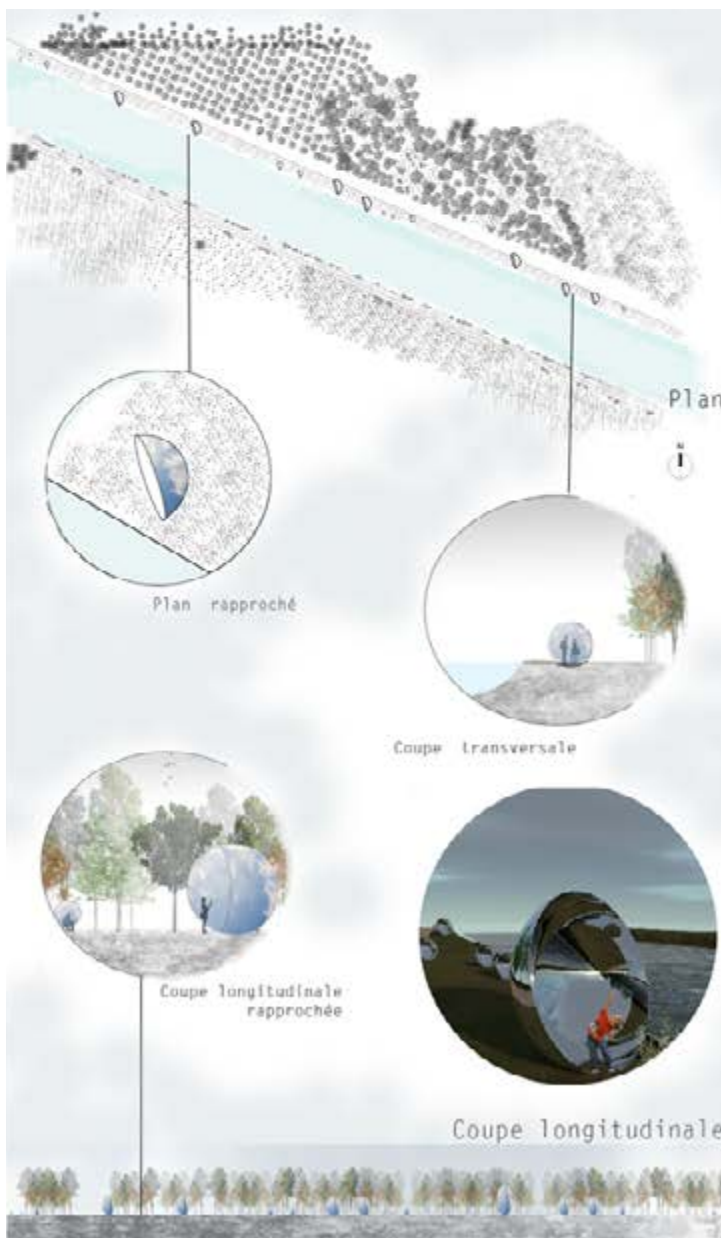



Perspective

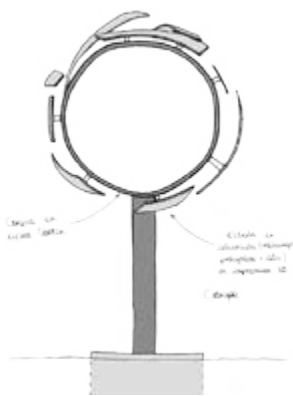
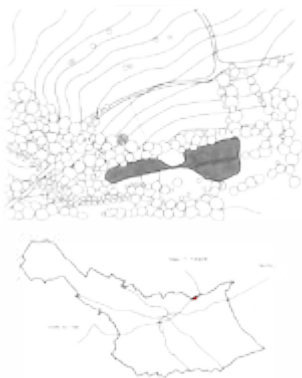
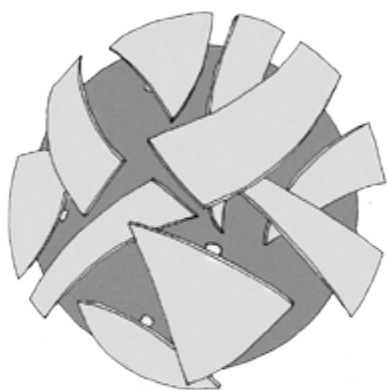





50M

50M

Plan



50M

Elévation Nord



Coupe longitudinale

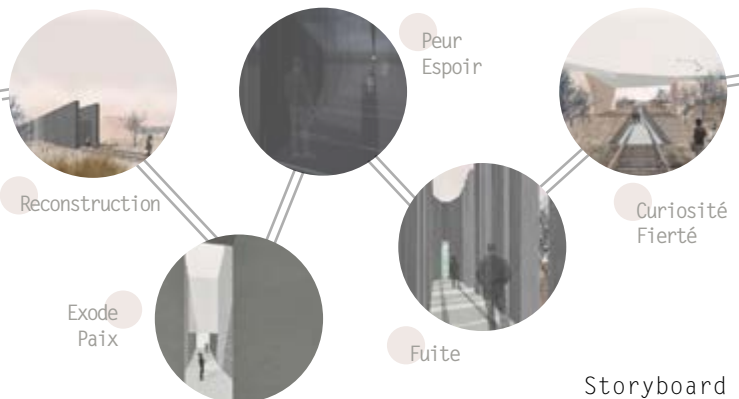

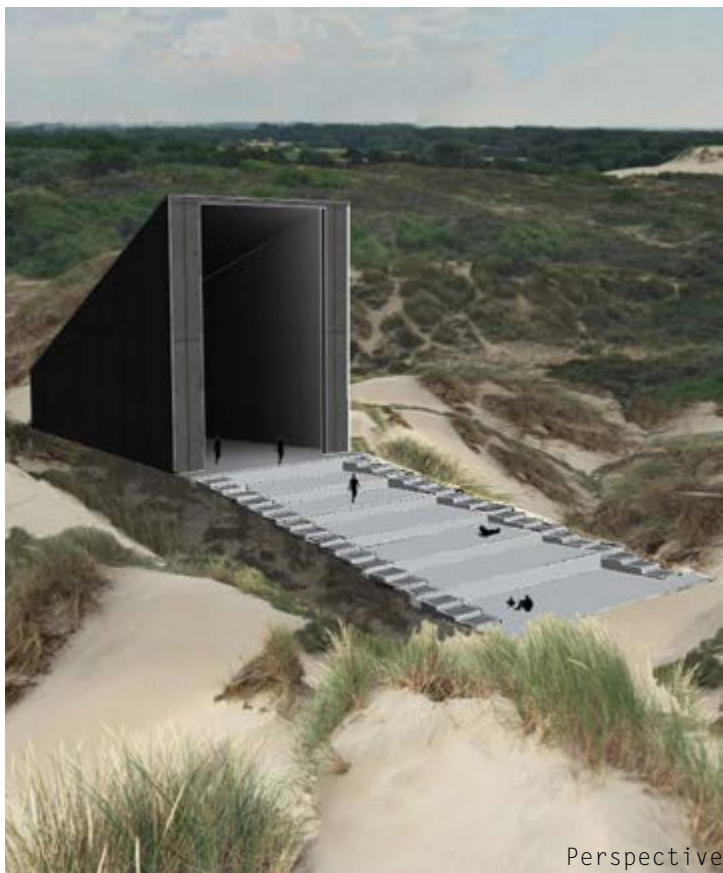

Perspective



Plan

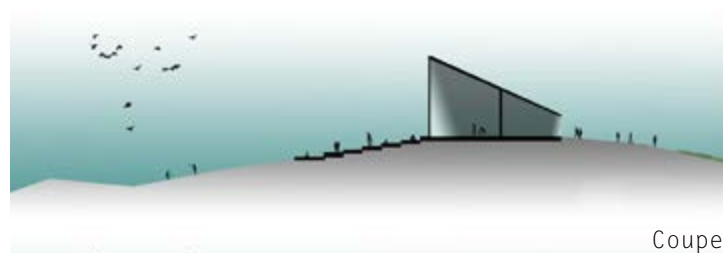

Coupe

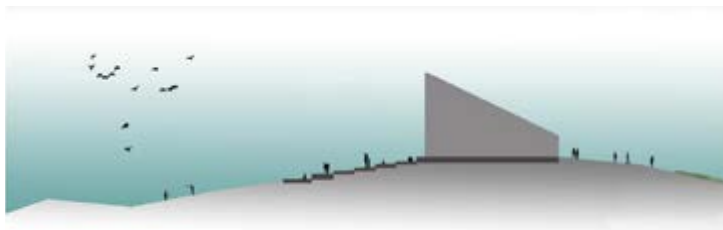

Élévation



Photographies



Perspective

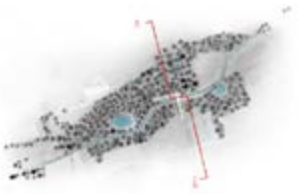

Plan masse

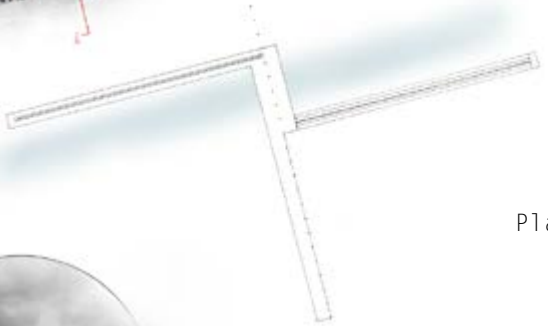

Plan

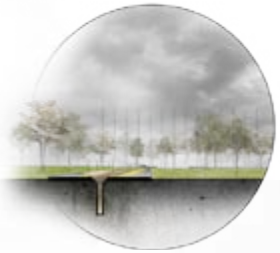
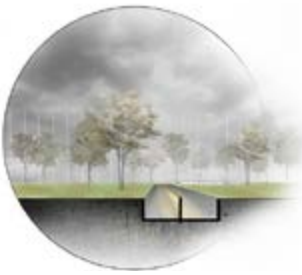

Coupes perspectives



Coupe paysagère



Perspective



Plan



Coupe

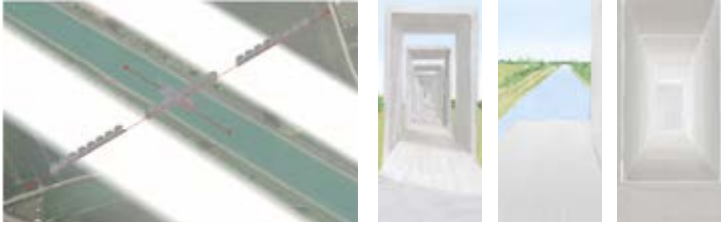

Schéma



Perspective



Plan



Coupe



Schéma





Perspective



Perspective

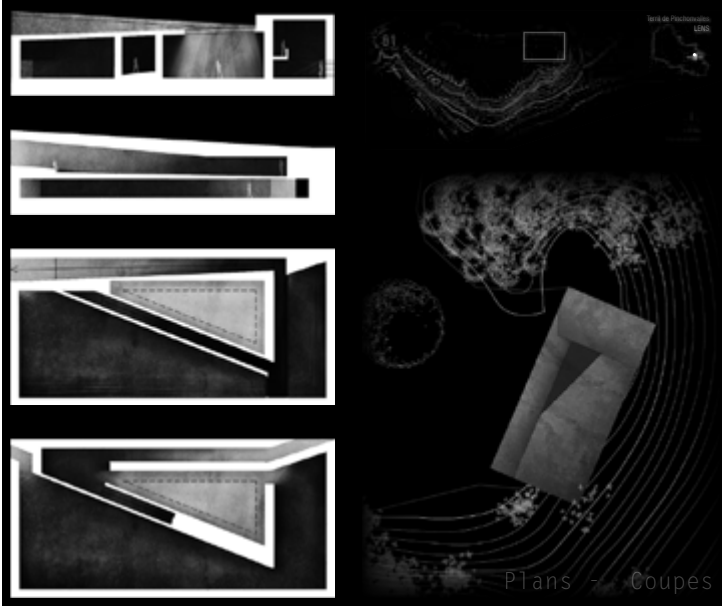

Plans - Coupes

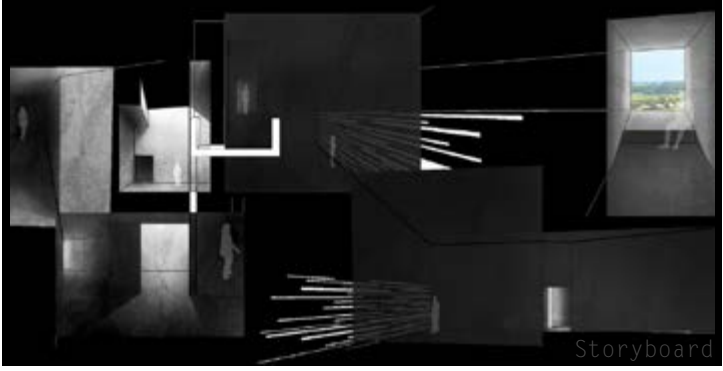

Storyboard



PLAN



ELEVATION



COUPE



SCHEMAS

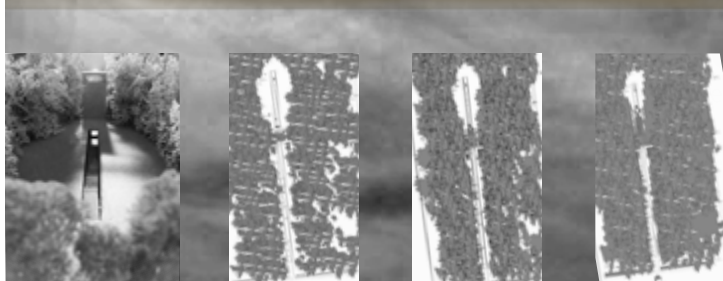
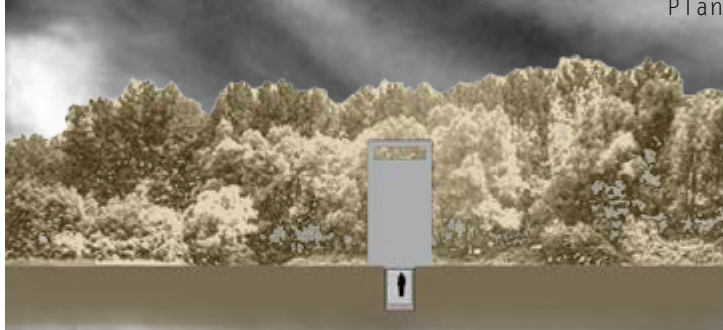



Plan

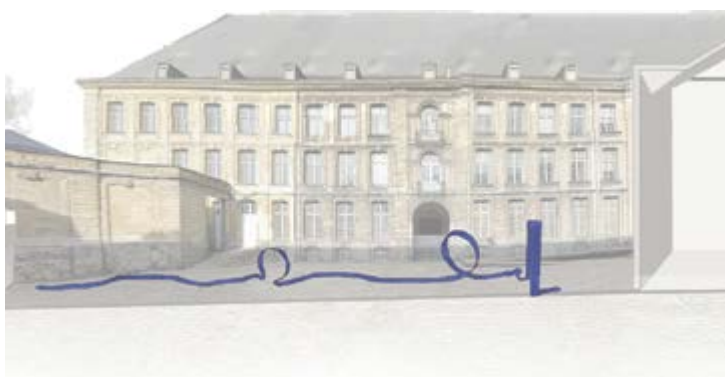

Schéma



Perspectives



Plan

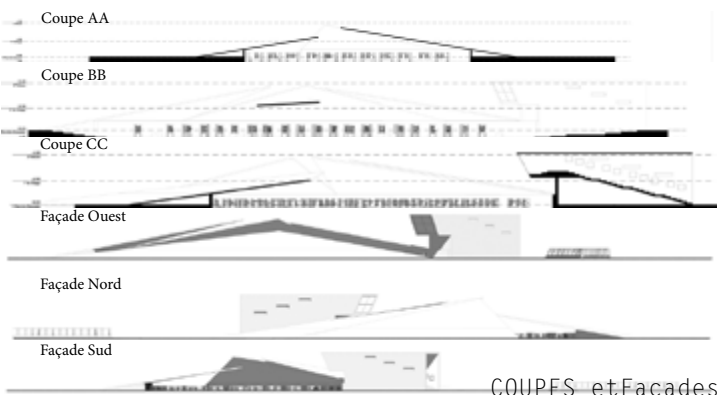

COUPES et Façades

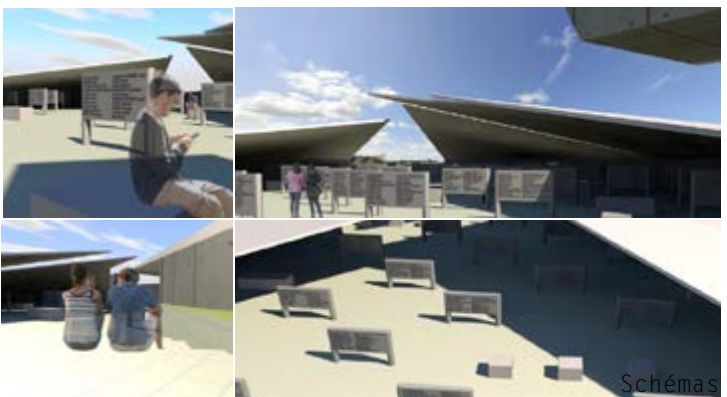

Schémas



Perspective



Intégration

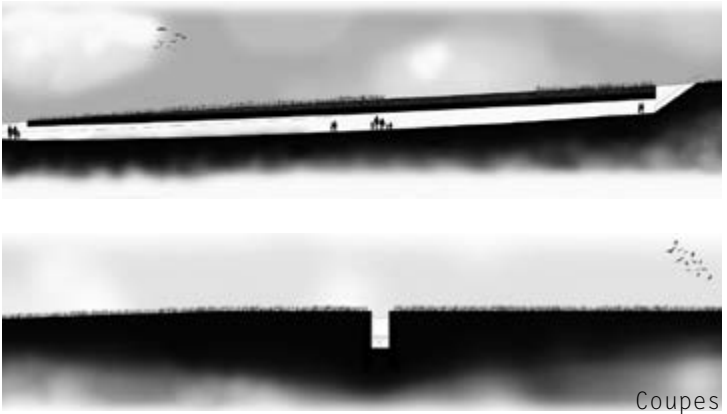

Coupes



Insertions



Mémorial du Mont-Saint-Eloi

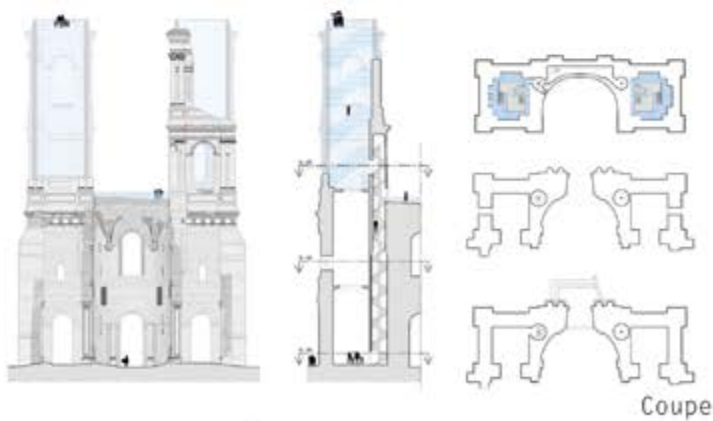

Schéma

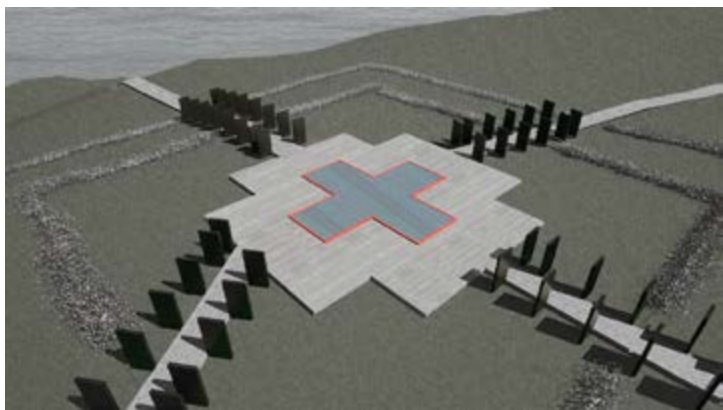

Perspective

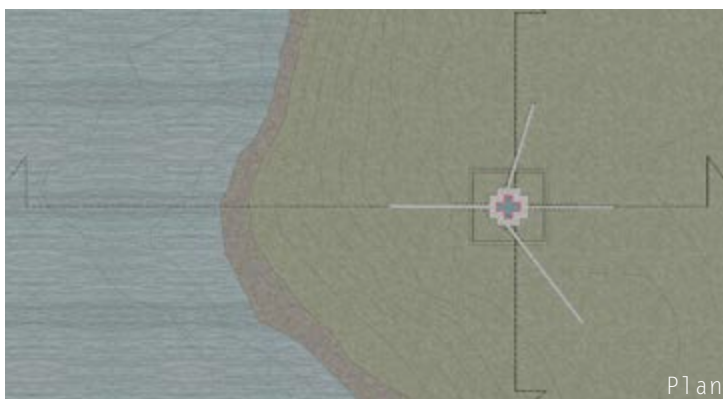

Plan

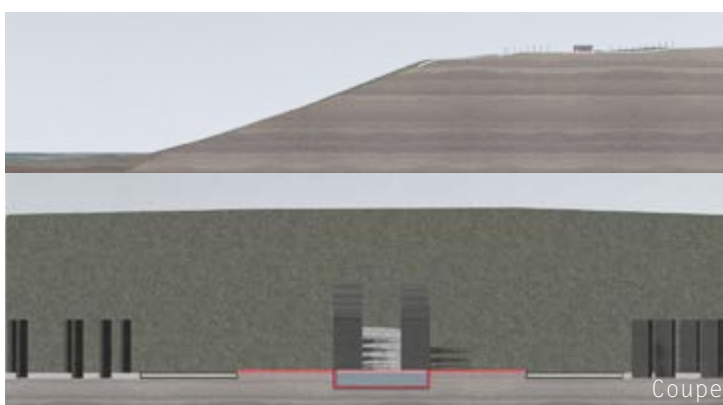

Coupe

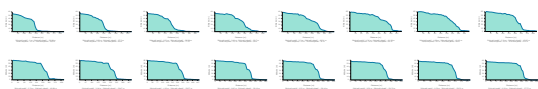

P  
A  
S  
D  
E  
C  
A  
L  
A  
I  
S  
P  
O  
I  
N  
T  
E  
D  
E  
L  
A  
C  
R  
E  
C  
H  
E



Schéma



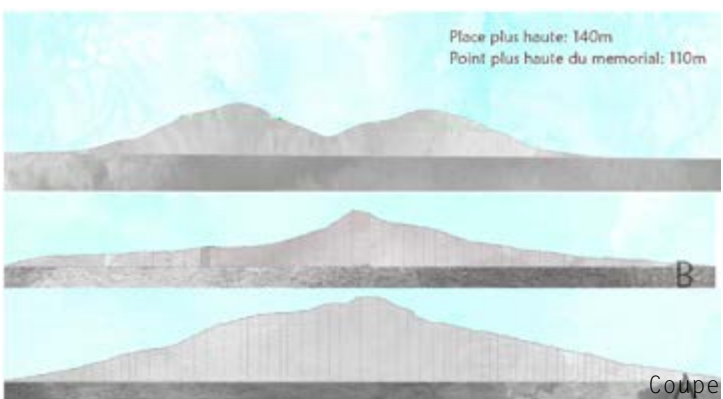

			
Voir et être vu	Lien=fraternité historique	Souvenirs du passé	Sensibilité
la hauteur fournit une visualisation correcte de l'endroit	Le lieu est à côté de Loos, en faisant un souvenir de la bataille	Tunnels et tranchées sont évoqués grâce aux passages intérieurs	L' utilisation d'un lieu déjà existant, en mettant un lien qui symbolise fraternité

Schéma



Perspective



Plan



Coupe

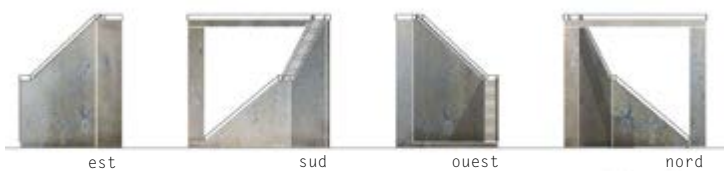

est

sud

ouest

nord



Schéma

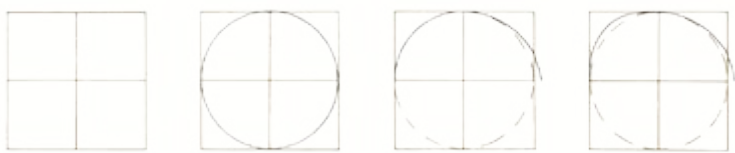

Plan masse



PASSAGE



LIBERTE



UNITE



Perspective intérieure



Perspective extérieure

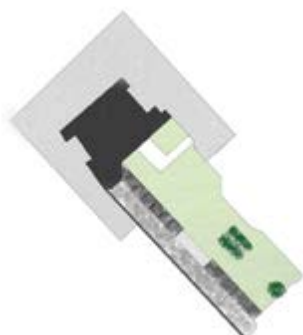

Plan



Plan masse



Coupe



Coupe

Concept

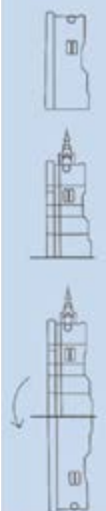

Localisation



Vue avec contexte



Coupe avec contexte

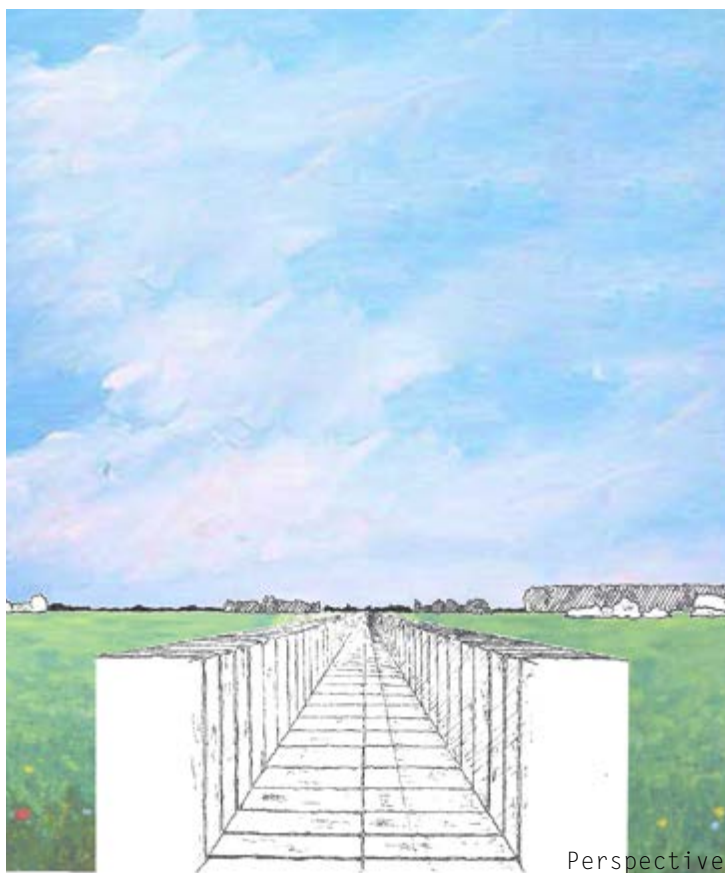

Perspective



Plan

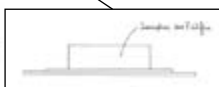
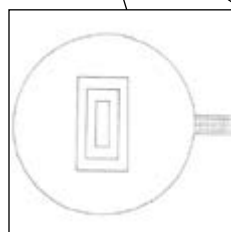

Schémas

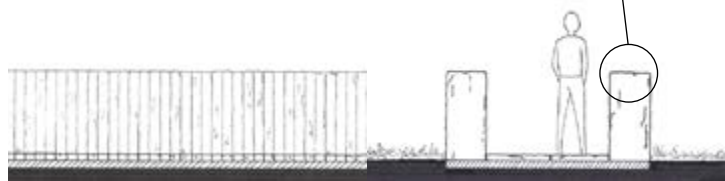

Coupes



Perspective



Plan

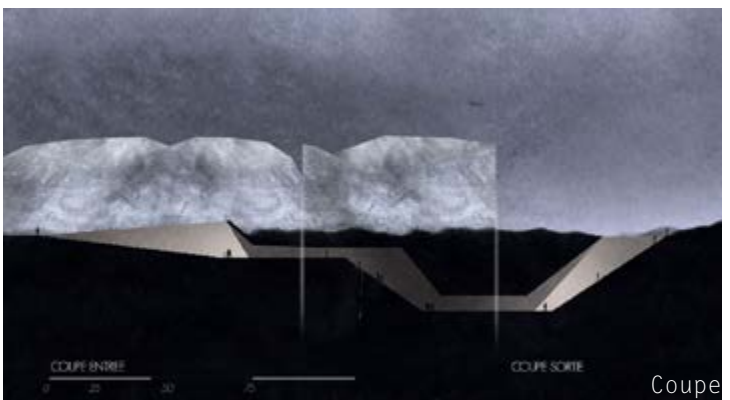

Coupe

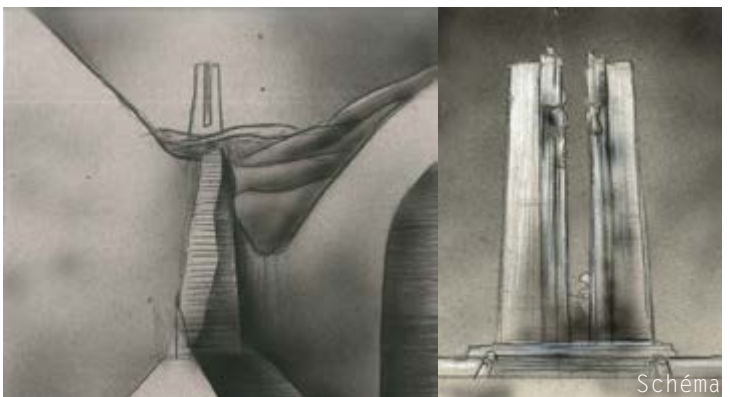

Schéma

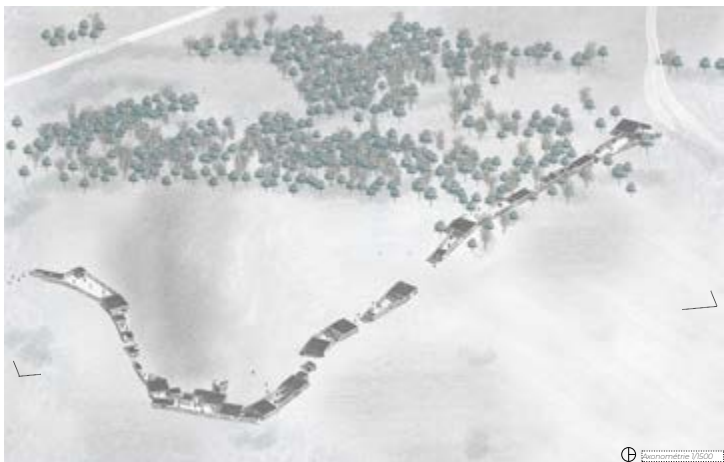

⊕ Escalatoire 1/500

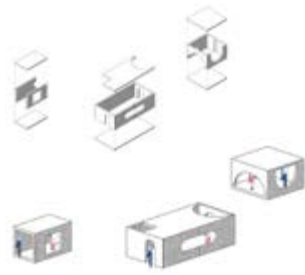

Escalade 1/500



Plan masse 1/100

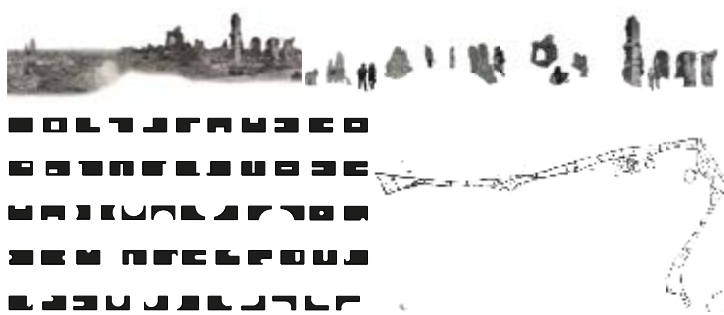



Perspective



Plan  
FORT DE RISBAN  
PORT DE CALAIS



Élévation

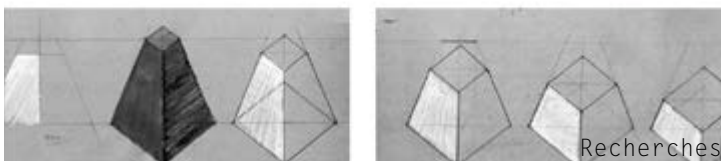
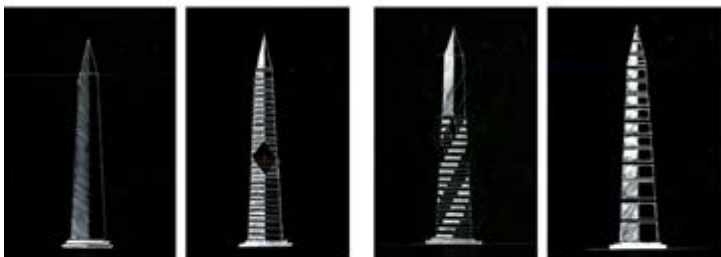

Recherches





Perspective



Plan



Coupe

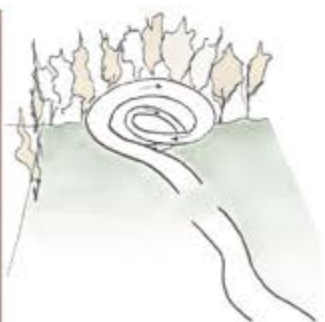

Schéma



Perspective

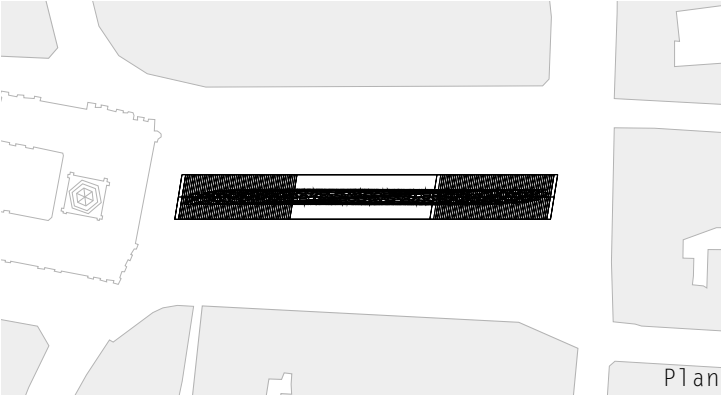

Plan

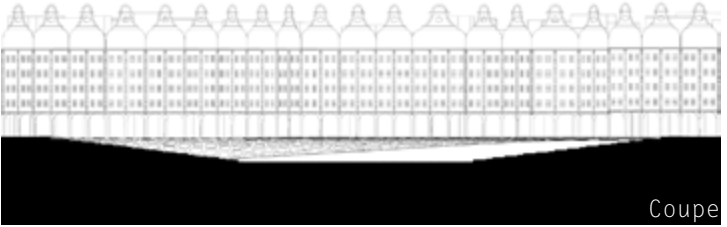

Coupe

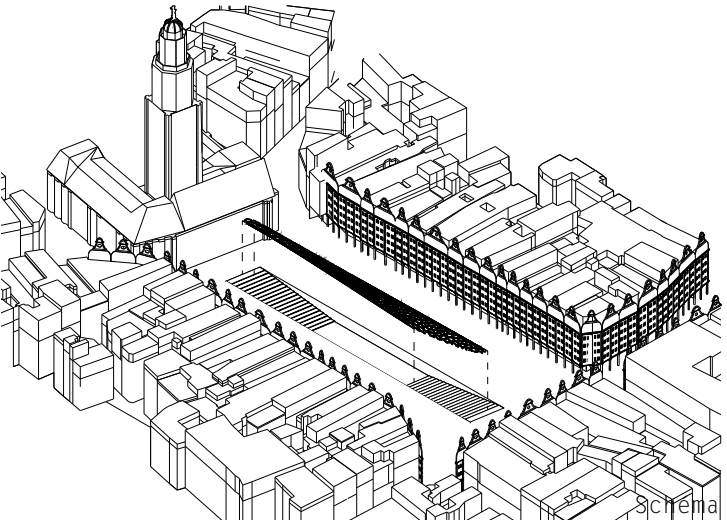

Schema

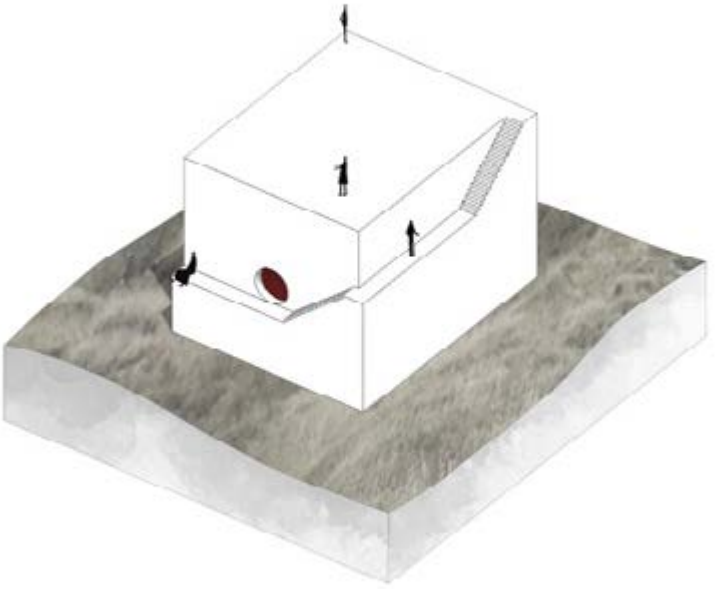

Perspective

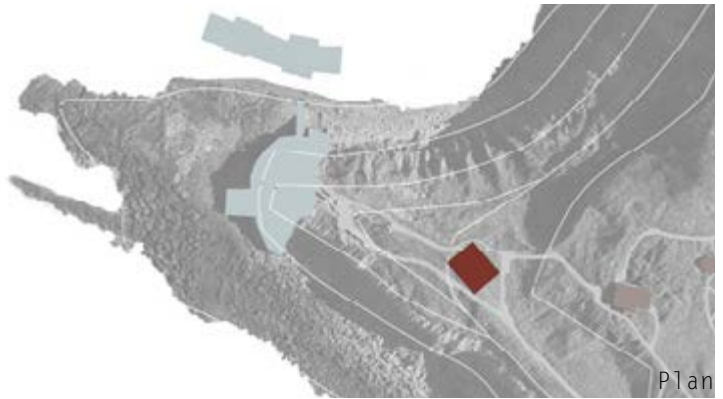

Plan



Coupe

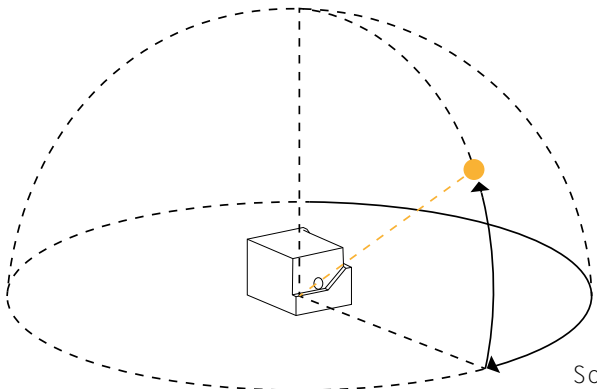

Schéma

